

# Instruction Manual

Intelligent Planimeter

---

PLACOM

**KP-21C**

# Contents

Section	Page
1	Important information before using the KP-21C . . . . . 1
2	Specifications . . . . . 2
3	Description of parts and keyboard explanation
3-1	Description of parts . . . . . 3
3-2	Keyboard explanation . . . . . 3
4	LCD panel . . . . . 4
5	Measurement Example
5-1	Basic Measurement . . . . . 5
5-2	Solids and Holes (calculating voids) . . . . . 7
6	Setting of each function
6-1	Set measurement item . . . . . 9
6-2	Set printer output . . . . . 10
6-3	Set LCD display . . . . . 10
6-4	Set reduced scale . . . . . 10
6-5	Input of known coordinates . . . . . 11
6-6	Set unit . . . . . 13
7	Other functions
7-1	Average measurement . . . . . 14
7-2	Cancellation key . . . . . 14
7-3	Auto-close function . . . . . 14
7-4	Auto-power off function . . . . . 14
7-5	Initialization operation . . . . . 15
8	Output of data
8-1	Printout format . . . . . 16
8-2	Data format . . . . . 17
9	Other items and options
9-1	Battery . . . . . 18
9-2	X - Y Coordinates . . . . . 18
9-3	Printer paper . . . . . 18

# [ 1 ] Important information before using the KP-21C

## Introduction

Thank you for purchasing the Intelligent Planimeter **PLACOM KP-21C**.

The **PLACOM KP-21C**'s design characteristics accede the design standards of the industry. The **PLACOM** series has the combination of high precision and easy to use functions, which will carry your engineering needs to meet the demands of the Information Technology revolution of the 21st century.

"What is a planimeter?" With the development of the **PLACOM KP-21C** emphasis was place on the precision of traced elements, which after all is the main point to any engineering problem. In addition, our goal was to create a measuring device with easy to use functions.

The main characteristics of the **PLACOM KP-21C** are as follows:

1. A high precision special encoder with its ergonomically designed tracing arm, may be "powered on" in any position. In other words, it is not necessary to clamp the tracing arm when you stop measuring briefly or look for zero, you can start measuring simply by turning on the power.
2. It is possible to measure not only area, which is the basis of the planimeter, but also coordinates.
3. Measurement of a line length and a section length are simple and with the touch of only the Plot-Key button you can measure any complex shape with ease.
4. The resulting data can be simply printed or sent to a personal computer.

The function of **PLACOM KP-21C** will be explained in this manual with exercises and figures. The following should be read at your convenience before you use the planimeter.

### Caution:

- Don't place in direct sunlight, especially hot or humid locations. Do not leave near a heater or open flame.
- Don't drop, bump or allow any sudden impact.
- Use a dry, soft cloth to clean. Don't use any wet dust cloths or volatile cleaners, such as paint thinner, benzene, etc.
- When you carry the planimeter, never grasp or carry it by the tracing arm.
- Use the planimeter on a clean smooth surface only. A desk or workstation, which has any texture or flaws, will hamper measurement. In addition, for accurate measurement. don't place the drawing on any other paper or drawings. The planimeter must be used on a single layer of paper that is directly on a flat work surface.
- Do not open or attempt to repair the planimeter. Contact your local retailer or Koizumi Sokki Mfg. Co., Ltd. for any warranty repairs. Failure to do so will void the guaranty.

## [ 2 ] Specifications

Measurement Functions: area, length, segmental length, coordinates

Units of Measurement: metric lengths: mm, cm, m, km  
metric area: mm<sup>2</sup>, cm<sup>2</sup>, m<sup>2</sup>, km<sup>2</sup>  
imperial lengths: in, ft, yd, mi  
imperial area: in<sup>2</sup>, ft<sup>2</sup>, acre, mi<sup>2</sup>

Display: 16 digit × 2 line dot matrix LCD

Measurement Range: X axis: 20m (±10m)  
Y axis: 380mm (±190mm)

Minimum Length: 0.05 mm ( at full-scale, 1:1)

Precision: within ± 0.1%

Computer Interface: serial communication via RS-232C cable

Power Supply: rechargeable Ni-Cd battery  
(Koizumi proprietary)

Operational Use: Continual use about 15 hours and the **KP-21C** can be used while recharging.  
Auto power off mode will begin 10 minutes after the last key operation.

Dimensions: Body with printer attachment:  
Length: 430 mm  
Width: 159 mm  
Height: 46 mm

Stored in carrying case: Length: 368 mm  
Width: 204 mm  
Height: 65 mm

Weight: 970 grams (printer attached)

Options: Koizumi exclusive printer model PR-2  
Accessories: paper roll  
exclusive AC adapter

Option: RS-232C cable (2m or 5m lengths)  
paper roll

## [ 3 ] Description of parts and keyboard explanation

### 3-1 Description of Parts

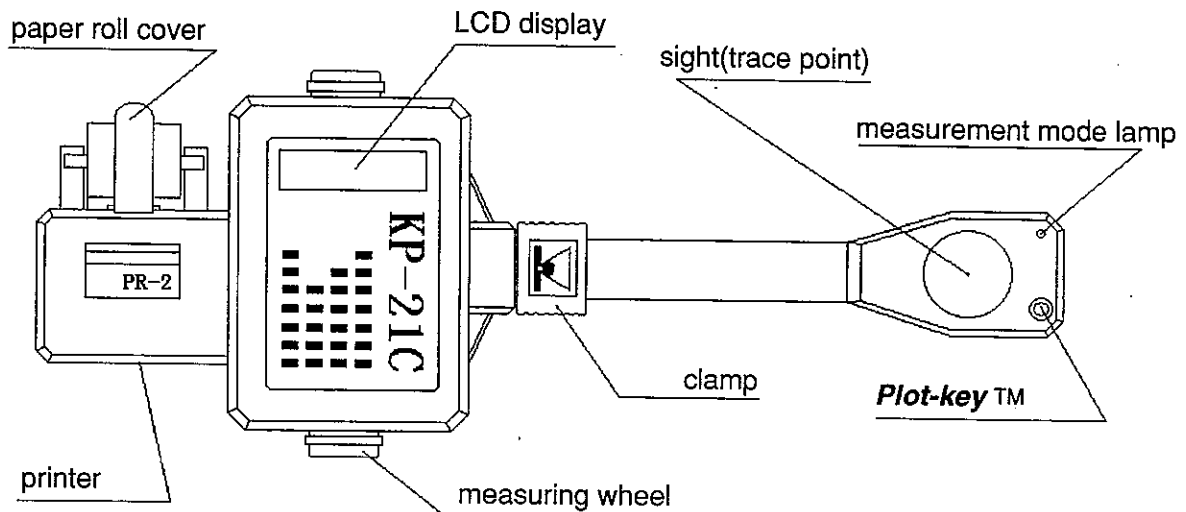

**Figure 3-1**

### 3-2 Keyboard Explanation

On/Off	Main power.
P.F.	Paper feed.
Set	Set measurement mode & set printer output.
Disp	Set display screen.
Can	Cancel.(cancel last data)
Scale	Set scale
B.P.	Base coordinate input.
Aver	Calculate average.
Hold	Hold the measurement data.
Unit M	Set scale to metric.
Unit I	Set scale to imperial.
Clear	Erase last data.
Enter	Confirmation key.
0 thru 9 & .	Numerical value and decimal point.
±	Change a value from positive to negative.
PLOT	Next to the trace lens, the <b>Plot-Key™</b> is mainly used while entering data.

## [ 4 ] LCD panel

Here are the main points of the LCD display while measuring and an explanation of each.

: This indicates a blank area in the LCD.

$H_D$  : Hold function is on.  
 : Hold function is off.

### Current Measurement Mode

**AREA:** Display Area  
**LINE:** Display Length  
**SPAN:** Display Segmental Length  
**COORD:** Display Coordinates

When "no measure" is displayed in the 2<sup>nd</sup> line, no measurement mode has been selected.

Displays the number of times  
 measurements have been taken.

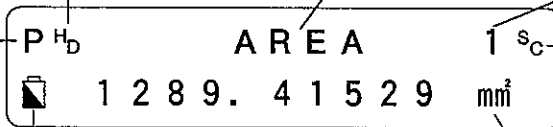

### Scale

$S_C$  : Scale is engaged.  
 : Scale is not engaged.

This character indicates the battery needs to be charged with the exclusive battery charger. The KP-21C is fully functional while it is being charged.

### Display Measurement Unit

metric lengths: mm, cm, m, km  
 metric area: mm<sup>2</sup>, cm<sup>2</sup>, m<sup>2</sup>, km<sup>2</sup>  
 imperial lengths: in, ft, yd, mi  
 imperial area: in<sup>2</sup>, ft<sup>2</sup>, acre, mi<sup>2</sup>

### Measurement Mode

**P** : Indicates point mode.  
**C** : Indicates curve line mode.  
 : The measurement wait.

### Other comments:

The other displays are explained in "Set Each Function" in this manual.

## [ 5 ] Measurement example First, let's try to measure a shape.

### 5-1 Basic Measurement

Let's look at Figure 5-1 and set up a similar design on desk or workstation and measure it. Before measuring can begin we must set some conditions. Place your design on a flat, smooth, clean surface and affix the design to the surface with tape, drafting dots or other suitable material to ensure no movement during the measurement. For this example let's assume we are measuring the entire area of Figure 5-1 with no voids.

- ① Measures all of the area, length, segmental length and coordinates  
(Refer to "Set measurement item" page 9)
- ② Set to full scale, 1:1  
(Refer to "Set reduced scale" page 10)
- ③ Choose metric "mm"  
(Refer to "Set unit" page 13)
- ④ Set the measurement mode to Area  
(Refer to "Set LCD display" page 10)
- ⑤ Choose output mode to printer  
(Refer to "Set printer output" page 10)

In the design point 1 and 2 are connected with a straight line. Point 2 to 3 is a curved line. The remaining points are connected with straight lines.

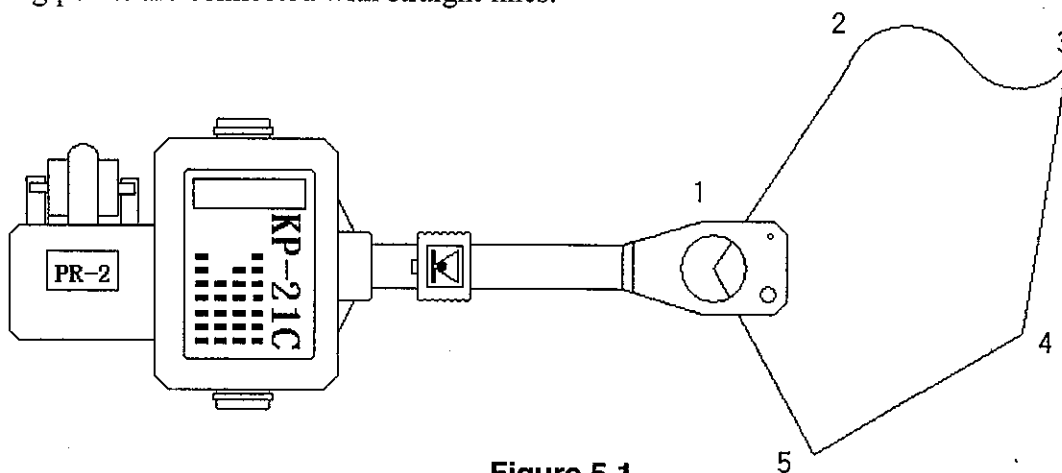

Figure 5-1

1. Slide the transport clamp to the right until it is fully released. You will feel it click into place. See Figure 5-2.
2. Press the (On / Off) key once to turn on the power.
3. Align the sight glass to place the red target over Point 1 and press the **(PLOT)** key once. The printer will print out coordinates and the LCD screen will look like Figure 5-3.

**(Note)** While the printer is operating the use of the **(PLOT)** key is restricted. After the printout has ended you may plot to the next point.

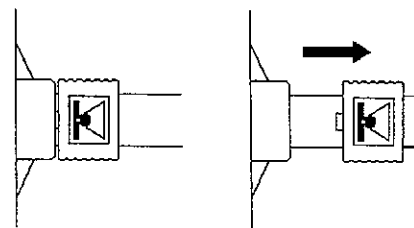

Figure 5-2

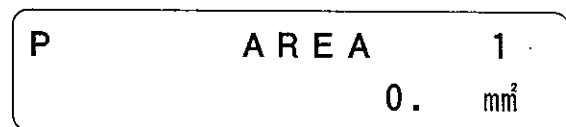



Figure 5-3

**(P)** in the upper left of the screen shows the measurement mode and **(1)** in the upper right shows the number of measurements.

4. Move the sight glass target to point 2 and press the **(PLOT)** key for a few seconds for the pilot lamp to illuminate. When it does release the **(PLOT)** key. This is to guide you along the curved line. Segmental length and coordinates will be printed out. The screen will look like Figure 5-4. The LCD will change to indicate a curved line measurement mode **(C)**.

<b>C</b>	<b>A R E A</b>	<b>1</b>
	2 1 2 . 7 8 2 3 5 8	mm <sup>2</sup>

**Figure 5-4**

 *The value displayed on the LCD screen while measuring is inconsequential.*

5. Trace the curved line to point 3 and press the **(PLOT)** key once. Segmental length and coordinates will print, and the mode will change to point measurement mode. The pilot lamp will go out and the screen will look like Figure 5-5.

<b>P</b>	<b>A R E A</b>	<b>1</b>
	8 5 3 . 8 7 4 4 2 3	mm <sup>2</sup>

**Figure 5-5**

6. Move directly to point 4 and press the **(PLOT)** key. Then continue to point 5 and press the **(PLOT)** key again. The screen will look like Figure 5-6.

<b>P</b>	<b>A R E A</b>	<b>1</b>
	1 1 4 9 . 8 6 2 1 1	mm <sup>2</sup>

**Figure 5-6**

7. Finally, move to point 1 and press the **(PLOT)** key **twice**. Segmental length and coordinates will be printed first. Area and length will print next and the buzzer will sound indicating the end of the measurement. The screen shown in Figure 5-7 will be displayed and the mode character **(P)** in the upper left of the screen goes out.

	<b>A R E A</b>	<b>1</b>
	1 2 8 9 . 4 1 5 2 9	mm <sup>2</sup>

**Figure 5-7**

 *When you want to display another measurement result, refer to "Set LCD display". And to see the contents printed out, refer to "Set printer output"*



## 5-2 Solids and Holes (calculating voids)

Now have a look at Figure 5-8 and set up a similar design on a workstation and measure it. As before we must set some conditions. Affix your design to the surface and with this example we will have a void or negative area such as a lake or a retention pond.

- |                                    |  |
|------------------------------------|--|
| ① Measures the area only           | (Refer to "Set measurement item" page 9) |
| ② Set to full scale, 1:1           | (Refer to "Set reduced scale" page 10)   |
| ③ Choose metric "mm"               | (Refer to "Set unit" page 13)            |
| ④ Set the measurement mode to Area | (Refer to "Set LCD display" page 10)     |
| ⑤ Choose output mode to printer    | (Refer to "Set printer output" page 10)  |

In the design point 1 and 2 are connected with a straight line. Point 2 to 3 is a curved line. The remaining points are connected with straight lines. The void area is an enclosed ellipse, data point 6.

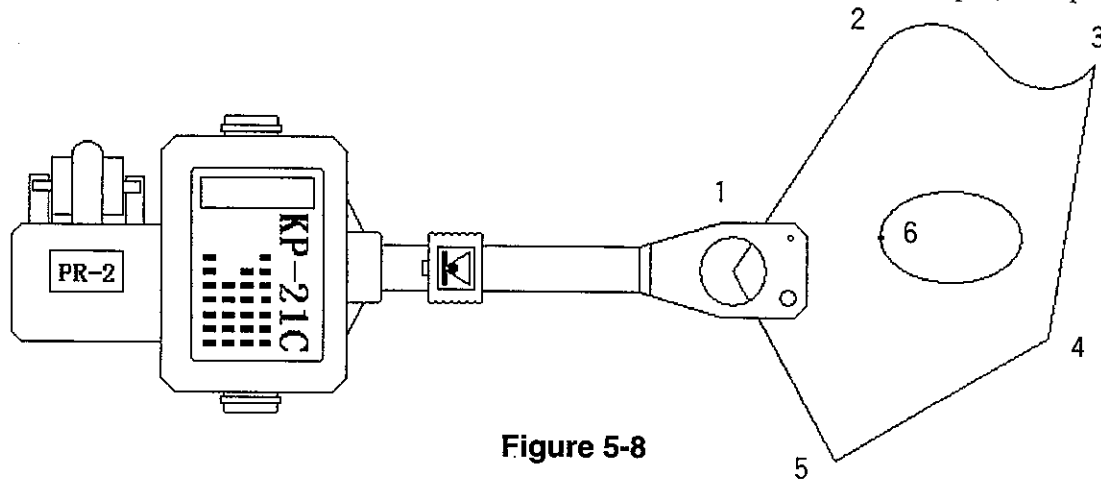

Figure 5-8

1. First measure outside area of the shape by the same procedure explained in **Section 5-1 Basic Measurement**. The display will show the total area as before, see Figure 5-9. Because the measurement item is area only, there is no printout of the segmental lengths or coordinates. Only resultant of area measurement is printed.

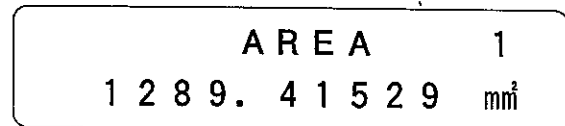

Figure 5-9

2. Press the **(Hold)** key, to hold the data from one area of a design while measuring the next area and the LCD will look like Figure 5-10.

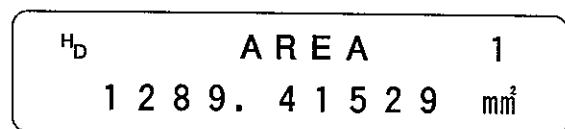

Figure 5-10

H<sub>D</sub> in the upper left of the screen shows that data is being held.

- When deducting an area, always move the sight glass in a counterclockwise motion like Figure 5-11. In other words, when you want to add a measurement move your points clockwise. When you want to deduct an area always move counterclockwise.

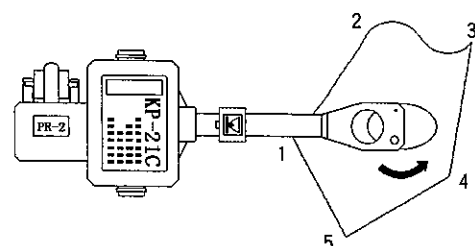

Figure 5-11

3. After fitting a sight point onto point 6, press the **PLOT** key for a few seconds to enable the measurement mode pilot lamp to illuminate. See Figure 5-12.

C	AREA	1
1 2 8 9 .	4 1 5 2 9	mm <sup>2</sup>

**Figure 5-12**

H<sub>b</sub> in the upper left of the LCD disappears and the measurement mode indicator **C** will appear.

4. Trace out the ellipse, starting from point 6 in a **counter-clockwise** direction and return to point 6 again. The Auto-Close function will close the shape when the target approaches the beginning point; while in curved line measurement mode, and after printing the information ends automatically with the buzzer sound. See Figure 5-13.

C	AREA	1
1 1 5 8 .	2 5 8 7 5	mm <sup>2</sup>

**Figure 5-13**

## [6] Setting of each function

### 6-1 Set measurement item

The KP-21C can measure area, length, segmental length and coordinates simultaneously. Or one can measure only specific items as you like.

1. Press the (Set) key on the keypad and in just a moment the LCD will appear like Figure 6-1.



```
1. MEASURE ITEM
2. PRINTER SET █
```

Figure 6-1

2. Press (1) on the keypad and select 1. MEASURE ITEM, see Figure 6-2.



```
* 1 AREA    * 2 LINE
* 3 SPAN    * 4 COORD
```

Figure 6-2

3. Select the item you want from the choices listed. For example, if you want length measurement press (2) for LINE and the cursor will flash over your selection. See Figure 6-3.



```
* 1 AREA    * 2 LINE
* 3 SPAN    * 4 COORD
```

Figure 6-3

4. Press your selection again and the asterisk mark next to the numeric will disappear. The LCD will look like Figure 6-4.



```
* 1 AREA    2 LINE
* 3 SPAN    * 4 COORD
```

Figure 6-4

5. To return to the previous screen just press the number again, the cursor will flash and the asterisk will reappear. See Figure 6-5.

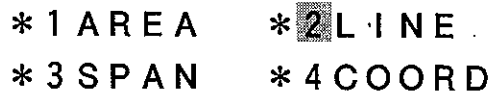

```
* 1 AREA    * 2 LINE
* 3 SPAN    * 4 COORD
```

Figure 6-5

6. Last press the (Set) key to confirm. The measurement item will be set and the LCD returns to the top of the measurement mode screen.

📄 When printer output is chosen, the data form "segmental length" and "coordinates" are printed out every time you plot. No print will occur during the calculation of area and length until the total has been inputted. To save battery power and paper it is advised that you do not select such items as segmental length and coordinates, unless they are needed.

### 6-2 Set printer output

When attaching a printer, you can choose printer output or no printout.

1. Press the **(Set)** key in the measurement mode screen. The LCD will look like Figure 6-6.
2. Press **(2)** and choose "2.PRINTER SET" The LCD will look like either Figure 6-7 or Figure 6-8.
3. When you choose printer output, Press **(1)**. And when not choosing printer output Press **(2)**. Then Press the **(Set)** key after choosing. The printer output choice is set and the LCD returns to the top of the measurement mode screen.



Figure 6-6

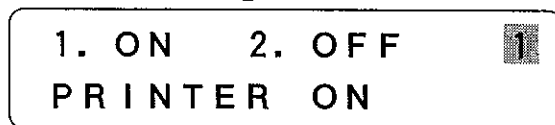

Figure 6-7

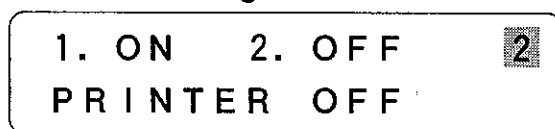
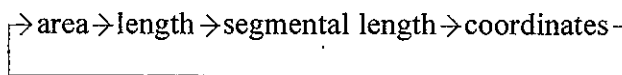

Figure 6-8

### 6-3 Set LCD display

Every time you press the **(Disp)** key, the measurement screen switches over in order,



Area screen



Figure 6-9

Length screen

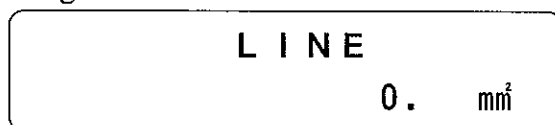

Figure 6-10

Segmental length screen

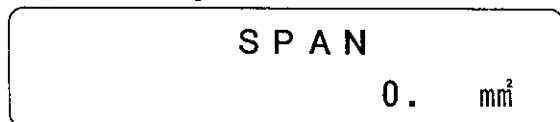

Figure 6-11

Coordinates screen



Figure 6-12

The screen, which isn't chosen as the measurement item, is displayed with "no measure" in the 2nd line like Figure 6-13.



Display of Coordinates screen

Figure 6-13

### 6-4 Set reduced scale

KP-21C can set reduced scale freely. Also, when you measure an area, it is possible to set the reduced scale individually for each axis.

1. Press the **(Scale)** key in the measurement mode screen. The LCD will look like Figure 6-14



Figure 6-14

2. First, input the reduced scale of the X axis.

For example, when you want to set up "1/50,000", input 50,000. If you make a mistake, Press the **Clear** key and re-input.

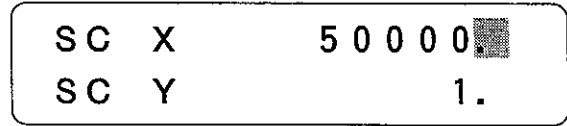
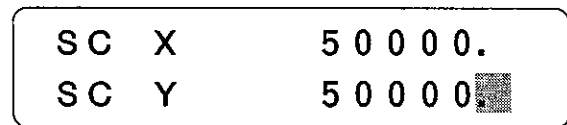

Figure 6-15

3. Press either the **Enter** key or the **Scale** key after inputting. The LCD will look like Figure 6-16.



The same reduced scale of the X axis will be inputted to the Y axis as well. The cursor will move to the Y axis automatically.

Figure 6-16

4. When you don't have to change anything, just keep it as is. If you want to change scale ratios, repeat the steps above. The reduced scale ratios are set and the LCD returns to the top of the measurement mode screen.

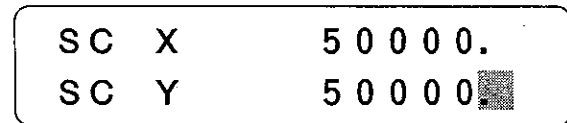

Figure 6-17

**☞** When reduced scales (except "1/1") is set in the X and Y axis, "SC" is displayed in the upper right corner of the measurement screen like Figure 6-18.



Figure 6-18

**☞** If you reduce scale without erasing the previous measurement, the measured value will be recalculated and there is possibility that an overflow will occur. The LCD will look like Figure 6-19.



Figure 6-19

### 6-5 Input of known coordinates

In any scale you can measure any other coordinates "If there are two known points" like Figure 6-20

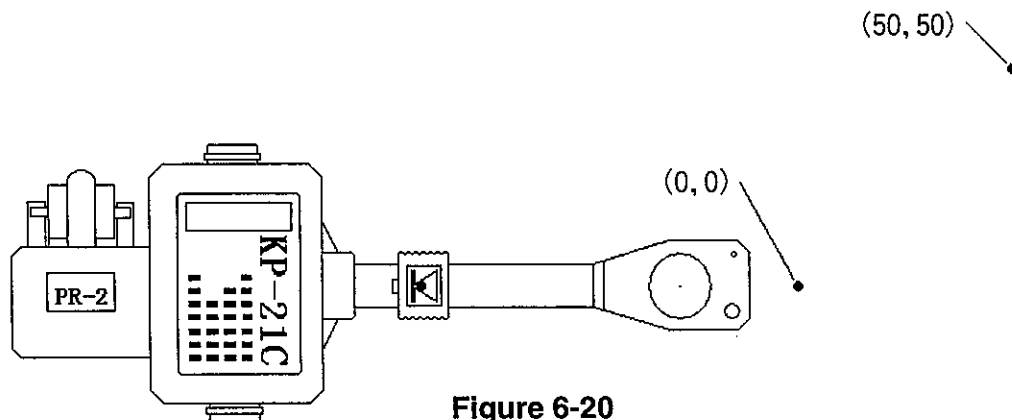

Figure 6-20

1. Press the **(B.P)** key in the measurement mode screen. The LCD will look like Figure 6-21. When you want to exit from this setting, press the **(B.P)** key.



Figure 6-21 (50, 50)

2. Put KP-21C on the either point and press the **(Plot)** key. The LCD will look like Figure 6-22.

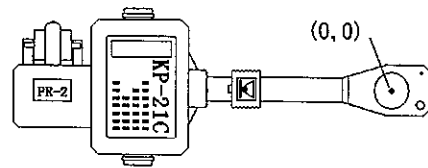

Figure 6-22

3. Input X coordinate. If you make a mistake, press the **(Clear)** key, and re-input. Press the **(Enter)** key or the **(B.P)** key after inputting. The LCD will look like Figure 6-23.



The cursor moves to Y coordinate.

Figure 6-23

4. Input Y coordinate in the same way. The LCD will look like Figure 6-24. When you want to exit from this setting, press the **(B.P)** key.

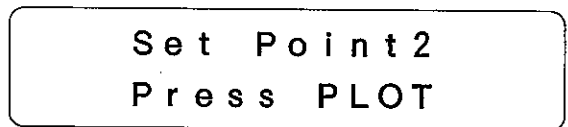

Figure 6-24

5. Move the sight point on the other point and press the **(Plot)** key.

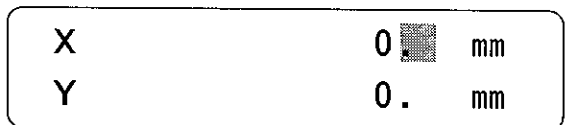
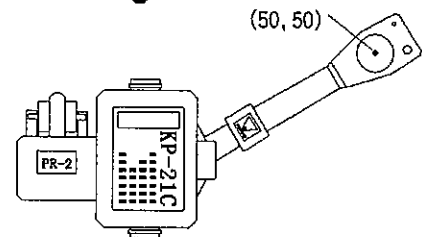

Figure 6-25

6. Input Y coordinate of the second point. The known point coordinates are set and the LCD returns to the top of the measurement mode screen.

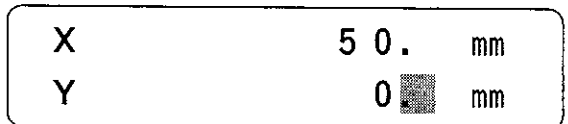

Figure 6-26

**(Note)** Don't put the same value in the specific coordinates of both points. It is thought of as one and it doesn't have any meaning.

By this setting, the reduced scale is calculated from both "measurement value" and "the inputted known point coordinate numeric" and set automatically. "sc" is displayed in the upper right of the measurement mode screen after setting.

On the other hand, when you change the reduced scale set by this "Input of known coordinates" with using procedure "6-4 Set of reduced scale", the set of known coordinates is erased.

## 6-6 Set unit

You can choose a measurement unit from either "Metric" or "Imperial" depending on the necessity.

- Every time you press the **Unit M** key in the measurement mode screen, it switches over to metric in order like below.

Length screen on the measurement mode screen  $\rightarrow$  mm  $\rightarrow$  cm  $\rightarrow$  m  $\rightarrow$  km

Area screen on the measurement mode screen  $\rightarrow$  mm<sup>2</sup>  $\rightarrow$  cm<sup>2</sup>  $\rightarrow$  m<sup>2</sup>  $\rightarrow$  km<sup>2</sup>

- Every time you press the **Unit I** key in the measurement mode screen, it switches over imperial in order like below.

Length screen on the measurement mode screen.  $\rightarrow$  in  $\rightarrow$  ft  $\rightarrow$  yd  $\rightarrow$  mi

Area screen on the measurement mode screen.  $\rightarrow$  in<sup>2</sup>  $\rightarrow$  ft<sup>2</sup>  $\rightarrow$  acre  $\rightarrow$  mi<sup>2</sup>

"in" = "inchs"  
 "ft" = "feet"  
 "yd" = "yards"  
 "mi" = "miles"

If you reduce the unit without erasing the previous measurement, the measured value will be recalculated and there is possibility that an overflow will occur. The LCD will appear like Figure 6-27.

AREA Overflow	1 mm <sup>2</sup>
------------------	----------------------

Display of area screen

Figure 6-27

## [ 7 ] Other functions

### 7-1 Average measurement

You can measure an area several times and then figure out the average for that area.

1. Confirm that the "number of times to measure" indicator isn't displayed in the upper right area of the screen. If there is a number in "the number of times to measure" display, it means that the previous data will remain in the memory. So press the **(Clear)** key to erase the previous data.

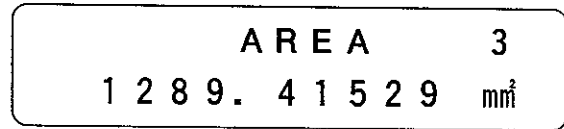

AREA 3  
1 2 8 9 . 4 1 5 2 9 mm<sup>2</sup>

↓ Figure 7-1



AREA  
0. mm<sup>2</sup>

Figure 7-2

2. Begin measurement. After the 1st measurement, the LCD will look like Figure 7-3.

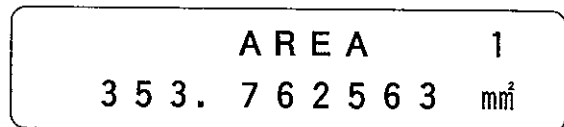

AREA 1  
3 5 3 . 7 6 2 5 6 3 mm<sup>2</sup>

Figure 7-3

3. In the same way, measure several times (within 10 times).

For example, when you want the average of 5 measurements, after the 5<sup>th</sup> measurement, the LCD will look like Figure 7-4

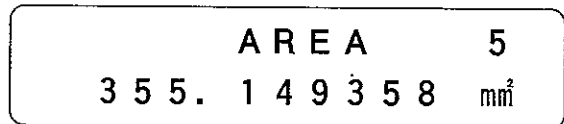

AREA 5  
3 5 5 . 1 4 9 3 5 8 mm<sup>2</sup>

Figure 7-4

4. The average is displayed when pressing the **(Aver)** key. Also, when you begin the next measurement, the memory is erased and the number of times to measure begins with "1". The LCD will look like Figure 7-5.

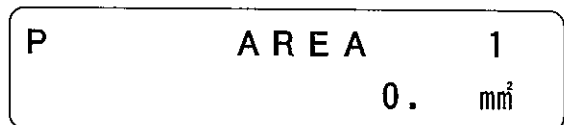

P AREA 1  
0. mm<sup>2</sup>

Figure 7-5

**(Note)** The number of times in which you may input data for an average is limited to 10 measurements. When you try the 11th measurement, all the previous measurement data is erased and the processes will revert back to the 1st measurement.

### 7-2 Cancellation key

When you plot by mistake while measuring on the point measurement mode, by pressing the **(Can)** key one can revert 1 step back to the previous condition. When you press the **(Can)** key again, all measurements stop and all the measurement data is erased.

### 7-3 Auto-close function

In case of curved line measurement mode, if the sight point approaches to "within 0.5 mm from the beginning point", it converges automatically and it ends the measurement.

### 7-4 Auto-power off function

When KP-21C is left on, the power supply is turned off automatically in 10 minutes after the last key operation. However, the set contents and the measurement data are stored.



### 7-5 Initialization operation

When you want to reset, it is possible to do so by following these steps. But be careful as it'll not only erase measurement data but also "Reduced scale ratios" and "Units" etc.

After turning off the power, press the **Clear** key and the **On** key at the same time. Then lift your finger off the **On** key first (before the **Clear** key). The LCD will look like Figure 7-6 along with a buzzer sound for a brief moment followed by the measurement mode screen.

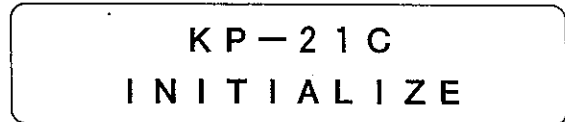

**Figure 7-6**

 *The initial memory is set as follows. This setting will be the same setting as at the purchase time.*

Measurement item	Measure all
Printer output	On
Reduced scale ratios	X axis : 1 / Y axis : 1
Known coordinates	No setting
Unit	Metric (mm <sup>2</sup> )
Measurement Data	Nil

## [ 8 ] Output of data

### 8-1 Printout format

Here is an explanation of the format using the contents which were printed out from "5-1 Basic measurement" as an example.

The 1<sup>st</sup> point information

X axis

Y axis

The 2<sup>nd</sup> point information

Segmental length of point 1 to 2

X axis

Y axis

The 6<sup>th</sup> point information

Segmental length of point 5 to 1

X axis

Y axis

Area

Length

```
# 0 0 0 1
X -0. 1 0 9 5 5 5 9 mm
Y 0. 9 4 9 1 0 6 1 4 mm
# 0 0 0 2
S 3 0. 9 4 7 9 8 9 6 mm
X 2 6. 4 3 1 6 2 9 1 mm
Y 1 6. 8 6 5 8 7 5 6 mm
# 0 0 0 6
S 2 5. 0 7 8 6 9 2 3 mm
X -0. 2 0 6 3 4 0 6 mm
Y 0. 8 4 0 4 3 3 2 4 mm
#####
A 1 2 9 6. 0 3 5 5 5 mm2
L 1 4 5. 6 2 2 1 6 9 mm
```

Area : "A" is at the front

Length : "L" is at the front

Segmental length : "S" is at the front

Coordinates : X axis "X" is at the front    Y axis "Y" is at the front

☞ When connected to another device such as computer via the optional RS-232C cable, this curved coordinate data can be saved and therefore printed later. However while in the curved line mode, the KP-21C will not print to the attached printer.

## 8-2 Data format

The data is composed of "17 bytes of ASCII code". Therefore it is almost the same as the printout format.

Communication condition Baud rate : 9600 bps  
Data bit : 8 bits  
Parity bit : Nil  
Stop bit : 1 bit

Data example is below.

Area data example : 7 9 4 7 . 4 1 1 1 9 mm<sup>2</sup>

A 7 9 4 7 . 4 1 1 1 9 m m .<sup>2</sup>  
41h,20h,37h,39h,34h,37h,2eh,34h,31h,31h,31h,39h,20h,6dh,6dh,5eh,0dh

Length data example : 3 4 6 . 8 8 9 5 6 9 mm

L 3 4 6 . 8 8 9 5 6 9 m m  
4ch,20h,33h,34h,36h,2eh,38h,38h,39h,35h,36h,39h,20h,6dh,6dh,20h,0dh

Segmental length data example : 5 4 . 4 2 4 1 3 4 1 mm

S 5 4 . 4 2 4 1 3 4 1 m m  
53h,20h,35h,34h,2eh,34h,32h,34h,31h,33h,34h,31h,20h,6dh,6dh,20h,0dh

Coordinates data example : X - 7 . 9 6 4 1 0 8 mm



X - 7 . 9 6 4 1 0 8 m m  
58h,20h,20h,2dh,37h,2eh,39h,36h,34h,31h,30h,38h,20h,6dh,6dh,20h,0dh

Y 3 4 . 5 8 9 5 9 9 1 mm

Y 3 4 . 5 8 9 5 9 9 1 m m  
59h,20h,33h,34h,2eh,35h,38h,39h,35h,39h,39h,31h,20h,6dh,6dh,20h,0dh

## [ 9 ] Other items and options

### 9-1 Battery

When the voltage of the battery becomes low,  is displayed in the lower left of the screen.  disappears when it has been charged by the exclusive AC adapter.

If you continue to use without charging or don't use it for a long period of time, the LCD will look like Figure 9-1. If Figure 9-1 appears, it's impossible to do any measuring. It is fully functional while charging.

The battery  
needs charging

Figure 9-1

### 9-2 X-Y Coordinates

If the known coordinates aren't set, the coordinates of KP-21C are like Figure 9-2.

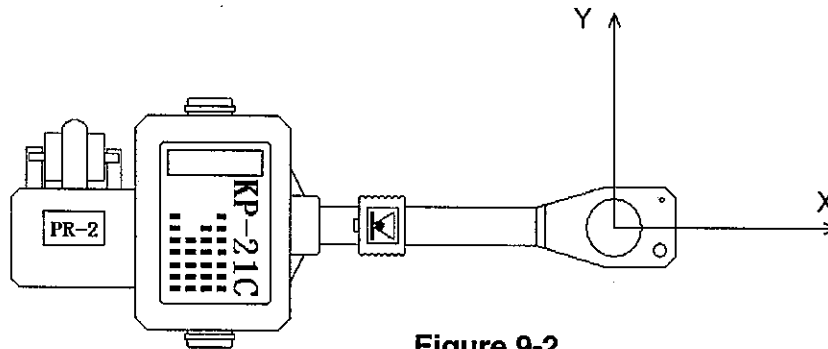



Figure 9-2

### 9-3 Printer paper

1. Turn the printer output setting on.
2. Insert the tip of the paper into the printer after checking that it's the correct side. Then lightly push the paper into the printer while continually pressing the (P.F) key.
3. When the printer pulls the paper by itself, you can lift your finger off the (P.F) key.

 Before inserting the paper, cut across the top diagonally and flatten the paper like Figure 9-3. This helps the printer to pull the paper better.

 The rolled paper has two sides. The correct side is the outside, which is the only side that is able to be printed on.

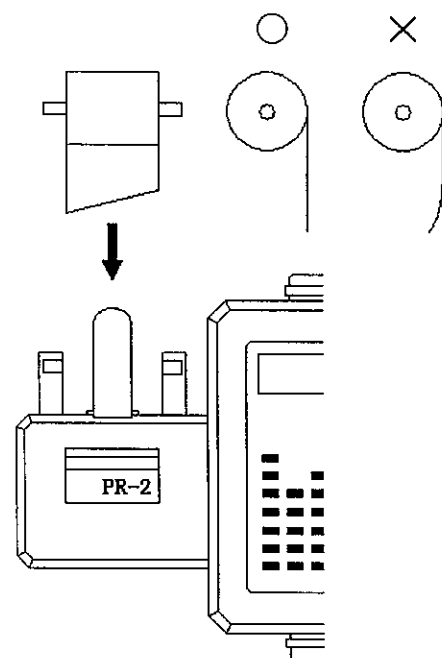

Figure 9-3